

User's manual

CB59
CB60
CB61



Description

This guide is designed to provide the most complete information about the CB59, CB60, CB61 encoder series and the EC-CB61-xx connection cable. This encoder is engineered to deliver a feedback signal to determine the speed of servo motors and gearless motors in particular. Furthermore an absolute signal (C/D absolute track) is generated to provide information about the position of the motor poles needful at motor start-up.



Table of contents

- 1 - Safety summary
- 2 - Identification
- 3 - Mounting instructions
- 4 - Electrical connections
- 5 - Output signals

1 - Safety summary

Safety

- Always adhere to the professional safety and accident prevention regulations applicable to your country during device installation and operation;
- installation and maintenance operations have to be carried out by qualified personnel only, with power supply disconnected and stationary mechanical parts;
- device must be used only for the purpose appropriate to its design: use for purposes other than those for which it has been designed could result in serious personal and/or the environment damage;
- high current, voltage and moving mechanical parts can cause serious or fatal injury;
- warning ! Do not use in explosive or flammable areas;
- failure to comply with these precautions or with specific warnings elsewhere in this manual violates safety standards of design, manufacture, and intended use of the equipment;
- Lika Electronic assumes no liability for the customer's failure to comply with these requirements.

Electrical safety

- Turn OFF the power supply before connecting the device;
- connect according to the explanation in the "4 - Electrical connections" section;
- wires of output signals which are not used must be insulated singularly;
- in compliance with 2014/30/EU norm on electromagnetic compatibility, following precautions must be taken:
 - before handling and installing the equipment, discharge electrical charge from your body and tools which may come in touch with the device;
 - power supply must be stabilized without noise; install EMC filters on device power supply if needed;
 - use the supplied connection cable only (code EC-CB61-xx);
 - avoid cables runs longer than necessary;
 - avoid running the signal cable near high voltage power cables;
 - mount the device as far as possible from any capacitive or inductive noise source; shield the device from noise source if needed;
 - minimize noise by connecting to ground (GND) the cable shield or the device housing. Make sure that ground (GND) is not affected by noise. The shield connection point to ground can be situated both on the device side and on user's side. The best solution to minimize interference must be carried out by the user.



Mechanical safety

- Install the device following strictly the information in the "3 - Mounting instructions" section;
- mechanical installation has to be carried out with stationary mechanical parts;
- do not disassemble the device;
- do not tool the device;
- delicate equipment: handle with care; do not subject the device to knocks or shocks;
- respect the environmental characteristics declared by the manufacturer.

2 - Identification

Device can be identified through data (order code and serial number) available in the label applied to its body. Information is listed in the delivery document. For any information on the technical characteristics of the product, refer to the technical catalogue.

3 - Mounting instructions



WARNING: installation and maintenance operations have to be carried out by qualified personnel only, with power supply disconnected and mechanical parts absolutely in stop. Do not tool the unit.

3.1 Installing the encoder

For correct installation a M5-threaded bore has to be provided in the motor shaft (see Figures below).

To install the encoder please follow carefully the next steps:

- unscrew the plastic cap (reference 3) on the back of the encoder;
- insert the encoder in the motor shaft and fix it using the provided M5 screw (reference 1);
- replace and tighten the plastic cap (reference 3) you previously removed;
- fasten the encoder to the motor frame through the fixing plate using the M3 screws (reference 2).

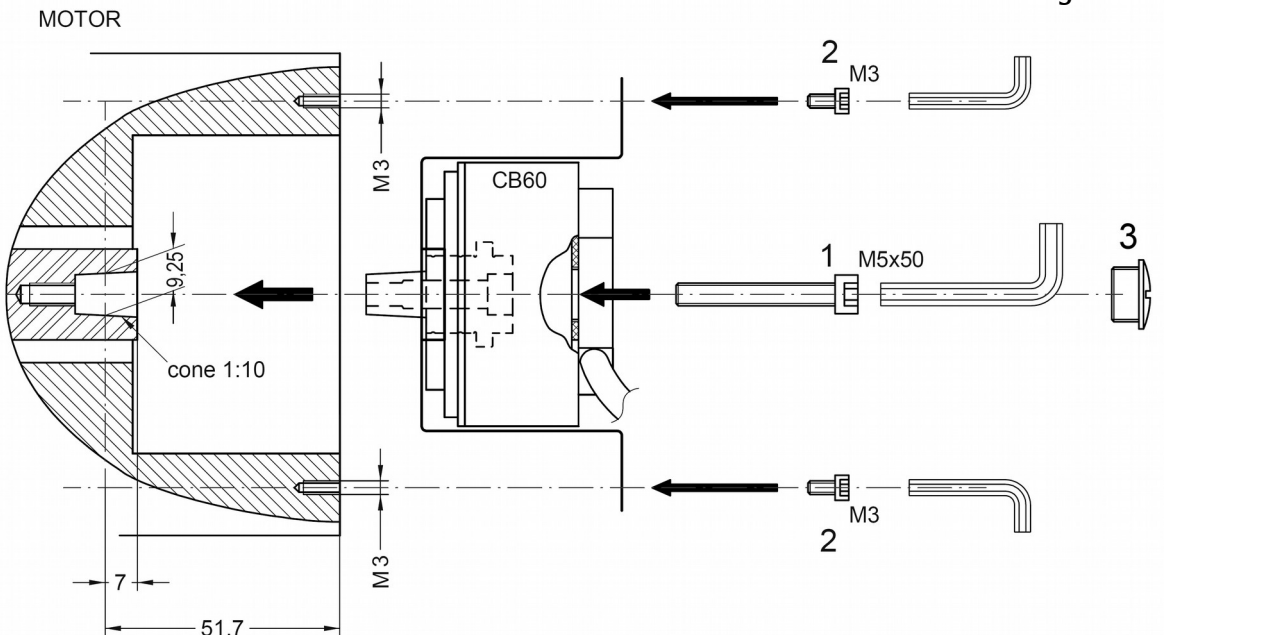
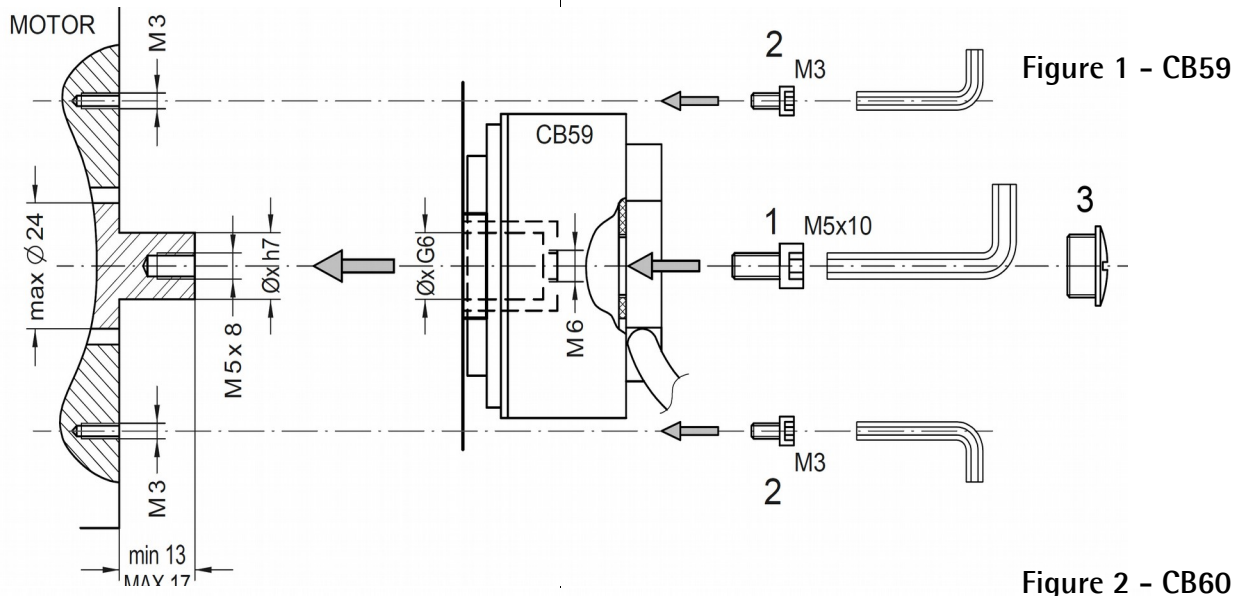

3.2 Dismounting the encoder

To dismount the encoder please follow carefully the steps described hereinafter:

- unscrew the fixing plate from the motor frame;
- remove the plastic cap **3** on the back of the encoder;
- remove the M5 screw **1** which fixes the encoder shaft to the motor shaft.



WARNING: do not force the encoder manually to pull it out!

- tighten a M6 screw instead of the M5 screw in the encoder shaft while ensuring the motor does not move (tightening the M6 screw will cause the encoder shaft to be drawn out slowly). To prevent the thread of the motor shaft from being damaged we suggest tightening a M5 grub screw before screwing in the M6 screw.

4 - Electrical connections



WARNING
Installation must be carried out with power supply disconnected.

Function	14-pin connector	TF12 cable
+5Vdc ±5%	13	Brown / Green
0Vdc	5	White / Green
A	3	Red
/A	12	Black
B	9	Green
/B	6	Brown
C *	1	Violet
/C *	14	Yellow
D *	11	Grey
/D *	4	Pink
0	7	White
/0	8	Blue
Shield	Shield	Case

* C / D signals of the absolute track are provided with option /1 only, see the order code

A, B signals: **Incremental** sine/cosine, 2048 pulses at each complete turn of the encoder shaft.

C, D signals: **Absolute** sine/cosine track, 1 sinusoidal period at each complete turn of the encoder shaft.



WARNING: C / D signals of the absolute track are provided with option /1 only, see the order code

0 signal: **Index "Z-track"**, 1 pulse at each complete turn of the encoder shaft.

4.1 98414-G05-14-LF 14-pin connector

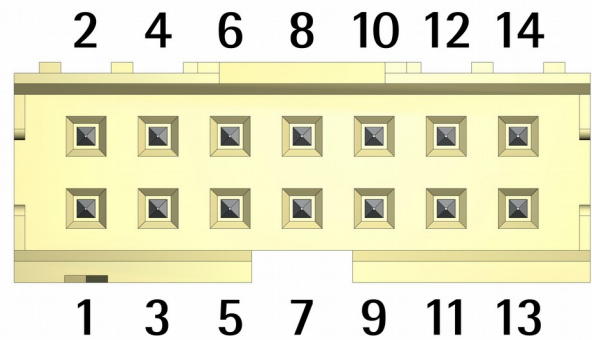

14-pin male connector

Female mating connector: SQW-107-01-F-D-VS

4.2 TF12 cable specifications

Twisted pairs : 6 x 2 x 28AWG
 Shield : braided copper
 Outside Ø : Ø 5.4 mm ± 0.1
 Impedance : < 242 Ohm/Km (20°C)
 (UL 758 tab.5.2.1)

4.3 Ground connection

To connect the cable shield we suggest gathering the shielding wires together and fixing them by means of a hexagonal metal gland crimped 25 mm from the connector. Be sure that the gland is in tight contact with the encoder's enclosure. Prevent the shielding wires from coming in contact with the internal electronics.

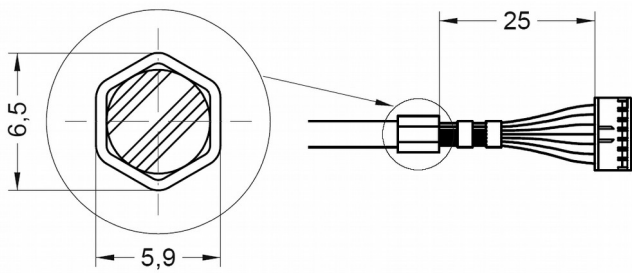

5 - Output signals

The frequency of the output signals is proportional to the shaft rotational speed.

If "Pulse rate" is **2048/x** (see the order code), then the encoder provides **2048 A** and **2048 B** sinusoidal pulses + **Z** track single pulse at each turn.

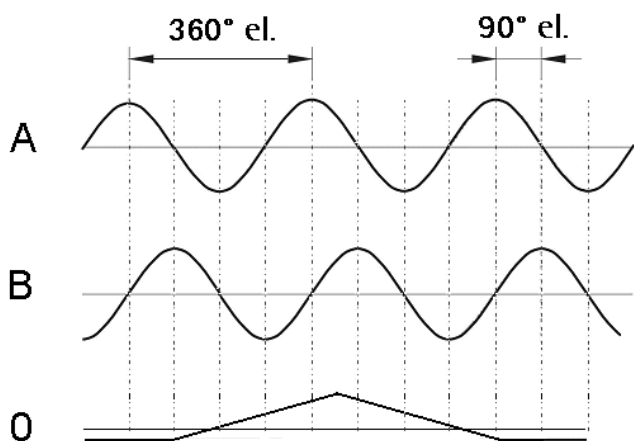

The encoder provides one **C** and **D** absolute sinusoidal signal at each turn (absolute track) only if "Pulse rate" is **2048/1** (see the order code).

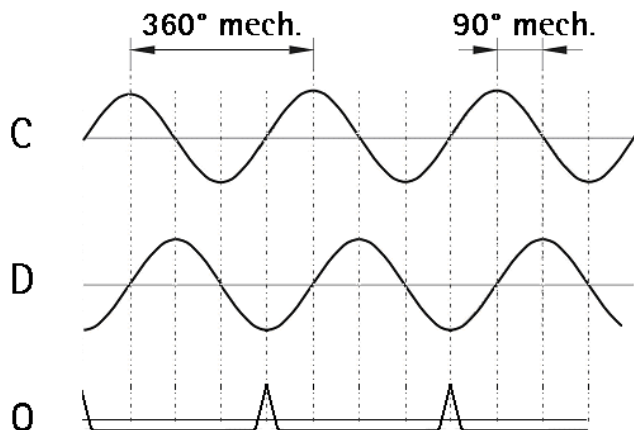

5.1 Output signals level

The voltage level refers to the differential value between normal and inverted signal (differential).

Recommended input circuit

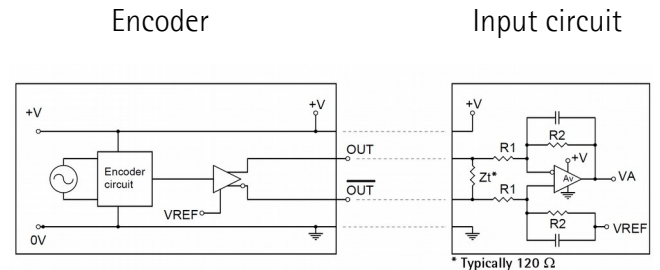

$$V_{REF} = 2.5V \pm 0.5V \quad V_A = 1V_{pp} * A_v \quad A_v = R2/R1$$

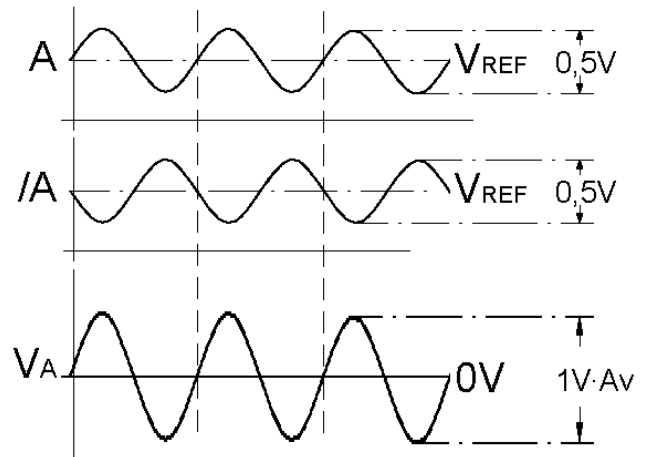

Document release	Description
1.0	1st issue
1.1	Added example in section 5
1.2	Updated paragraph 6.1
1.3	Updated section 4
1.4	Updated sections 1, 3.1 and 4
1.5	Added CB60
1.6	Updated section 4
1.7	Updated section 4
1.8	Updated sections 1 and 3.1
1.9	Added CB61
1.10	Updated section 4
1.11	Updated section 3
1.12	Web links updated
1.13	Italian / English separate editions, new option /0 without absolute track
1.14	14-pin connector



This device is to be supplied by a Class 2 Circuit or Low-Voltage Limited Energy or Energy Source not exceeding 30 Vdc. Refer to the order code for supply voltage rate.
 Ce dispositif doit être alimenté par un circuit de Classe 2 ou à très basse tension ou bien en appliquant une tension maxi de 30Vcc. Voir le code de commande pour la tension d'alimentation.

Dispose separately

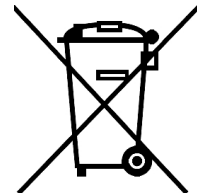

Lika Electronic
 Via S. Lorenzo, 25 - 36010 Carrè (VI) - Italy
 Tel. +39 0445 806600
 Fax +39 0445 806699
 Italy: eMail info@lika.it - www.lika.it
 World: eMail info@lika.biz - www.lika.biz